

# High Mast Lighting Poles

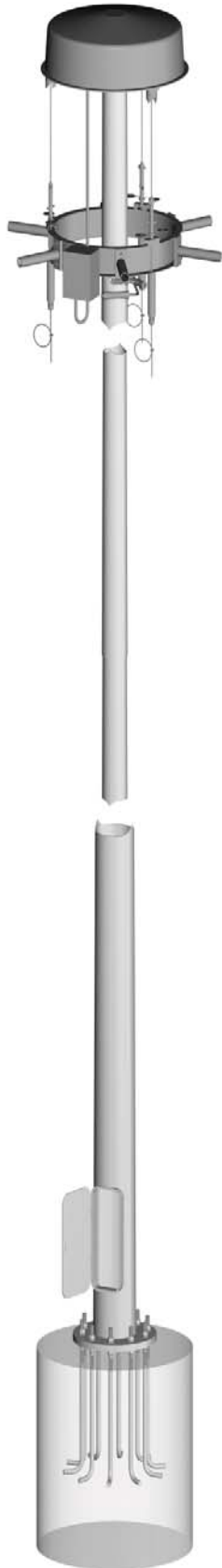

## General

American LitePole offers a raising and lowering system that allows for ease of maintaining the lighting system at ground level. Ideal where lift trucks and/or climbing is prohibited. Light fixtures can be arranged symmetrically for lighting prison yards, roadways or parking lots. Not to be excluded is Sports Lighting. The lowering device can also arrange light fixtures asymmetrically. This will allow for multiple sports fixtures to be aimed in one direction. Contact us for further details.

## Design

The selection of the correct pole design is predicated on the specific loading requirements of each application. The poles located in the steel pole chart are designed to withstand dead loads and theoretical dynamic loads developed by sustained winds of 80 MPH through 110 MPH times the 1.3 gust factor. The combined EPA and the weight of the luminaire, light support brackets, platforms and any other attachments cannot exceed the rated EPA or allowable weight on that pole.

## Welding

All welds shall be of the highest quality and performed by American Welding Society certified welders conforming to the latest version of the American Welding Society specification AWS D1.1.

## Finish

All poles, mounting brackets and platforms are furnished with a coating of either red oxide/zinc primer, factory painted, powder coated or hot-dip galvanized to ASTM A-123. Miscellaneous hardware will be galvanized to ASTM A-153. Exterior finish coatings are available by request.

## Pole Shaft

The steel pole shall consist of the appropriate number of pole sections, either round or multi-sided, for heights up to 120 feet. Each section shall be fabricated from high strength low alloy steel conforming to ASTM A-572, with a minimum yield strength of 55,000 psi. These shafts shall telescope over each other to match the overall desired pole height. The overlap telescoping joint shall have a length that is the larger of 2 feet or 1-1/2 times the diameter of the inside of the female tube. The sections shall be pre-fitted and match marked at the factory. All sections shall maintain a uniform taper from top to bottom. There shall be at least one longitudinal seam weld in the tapered section of the shaft. The longitudinal seam weld shall have at least 60% penetration, except in the areas where the shaft section telescopes over another. In overlapping areas, the weld penetration shall be 100%. No circumferential weld splices may be used in fabricating the shafts.

## Base Plate

The base plate is fabricated from a structural quality hot rolled carbon steel plate that meets or exceeds ASTM A-36 with a minimum yield of strength of 36,000 psi. The base plate shall telescope the pole shaft and have a circumferential weld on the top and bottom or shall have a full penetration butt weld with a back up bar. The anchor bolt holes shall be slotted and will be a minimum 1/4" larger than the diameter of the anchor bolts used on the pole.

## Hand Hole

A reinforced 10" x 30" hand hole will be installed 30" above base plate with a hinged, lockable door. A winch plate will be welded inside the pole, opposite the hand hole.

## Anchor Bolts

Anchor bolts are fabricated from a commercial quality hot-rolled carbon steel bar that meets or exceeds minimum yield strength of 55,000 psi. Anchor bolts are sized according to each pole design and are furnished with 2 galvanized heavy hex nuts and 2 galvanized flat washers. Anchor bolts shall be galvanized a minimum of 6 inches on the threaded end in accordance with ASTM A-153. Anchor bolts will ship with the poles unless otherwise noted.

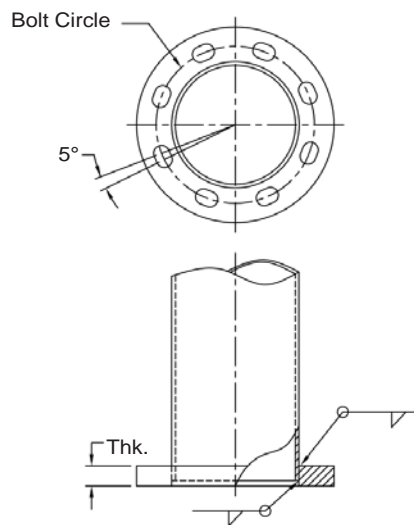

**Base Plate Detail**

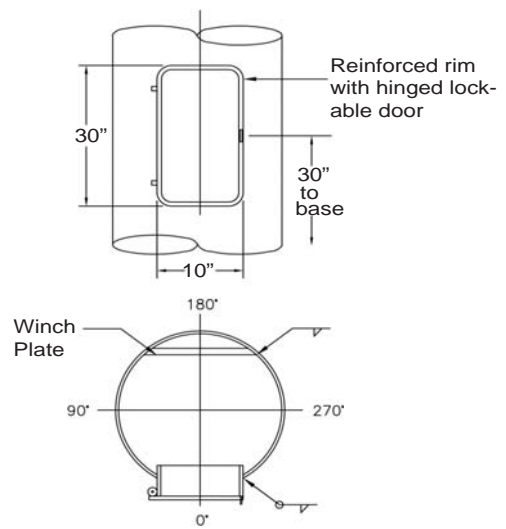

**Hand Hole Detail**



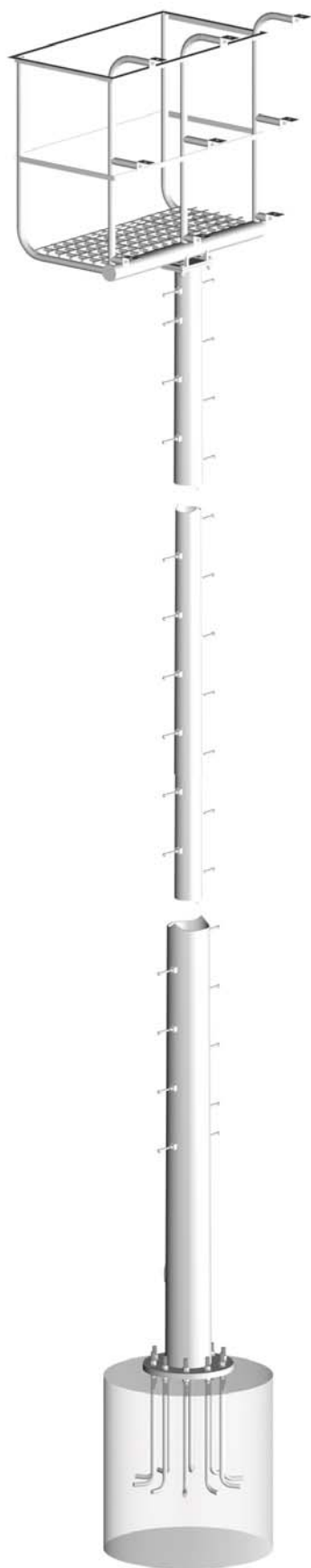

### Design

The selection of the correct pole design is predicated on the specific loading requirements of each application. The poles located in the steel pole chart are designed to withstand dead loads and theoretical dynamic loads developed by sustained winds of 80 MPH through 110 MPH times the 1.3 gust factor. The combined EPA and the weight of the luminaire, light support brackets, platforms and any other attachments cannot exceed the rated EPA or allowable weight of that pole.

### Welding

All welds shall be of the highest quality and performed by American Welding Society certified welders conforming to the latest version of the American Welding Society specification AWS D1.1.

### Finish

All poles, mounting brackets and platforms are furnished with a coating of either red oxide/zinc primer, factory painted, powder coated or hot-dip galvanized to ASTM A-123. Miscellaneous hardware will be galvanized to ASTM A-153. Exterior finish coatings are available by request.

### Pole Shaft

The steel pole shall consist of the appropriate number of pole sections, either round or multi-sided, for heights up to 120 feet. Each section shall be fabricated from high strength low alloy steel conforming to ASTM A-572, with a minimum yield strength of 55,000 psi. These shafts shall telescope over each other to match the overall desired pole height. The overlap telescoping joint shall have a length that is the larger of 2 feet or 1-1/2 times the diameter of the inside of the female tube. The sections shall be pre-fitted and match marked at the factory. All sections shall maintain a uniform taper from top to bottom. There shall be at least one longitudinal seam weld in the tapered section of the shaft. The longitudinal seam weld shall have at least 60% penetration, except in the areas where the shaft section telescopes over another. In overlapping areas, the weld penetration shall be 100%. No circumferential weld splices may be used in fabricating the shafts.

### Base Plate

The base plate is fabricated from a structural quality hot rolled carbon steel plate that meets or exceeds ASTM A-36 with a minimum yield of strength of 42,000 psi. The base plate shall telescope the pole shaft and have a circumferential weld on the top and bottom or shall have a full penetration butt weld with a back up bar. The anchor bolt holes shall be slotted and will be a minimum 1/4" larger than the diameter of the anchor bolts used on the pole.

### Hand Hole

An oval reinforced hand hole, having a nominal 4" x 6" x .25" wall, will be installed 18" above the base plate. A hand hole cover and attaching hardware is included with each hand hole assembly. A ground lug will be welded inside the pole opposite the hand hole. This is standard on all poles unless otherwise specified.

### Anchor Bolts

Anchor bolts are fabricated from a commercial quality hot-rolled carbon steel bar that meets or exceeds minimum yield strength of 55,000 psi. Anchor bolts are sized according to each pole design and are furnished with 2 galvanized heavy hex nuts and 2 galvanized flat washers. Anchor bolts shall be galvanized a minimum of 6 inches on the threaded end in accordance with ASTM A-153. Anchor bolts will ship with the poles unless otherwise noted.

### Pole Top

Each pole will be provided with either a removable pole cap, flat plate, or 2 3/8" O.D. x 5" tenon top (other sizes available).

**Complete factory pre-wired system available. Please consult factory for details.**

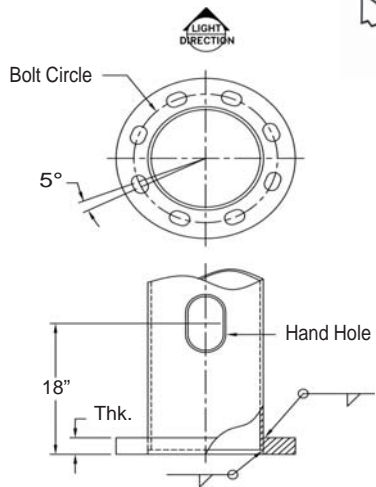
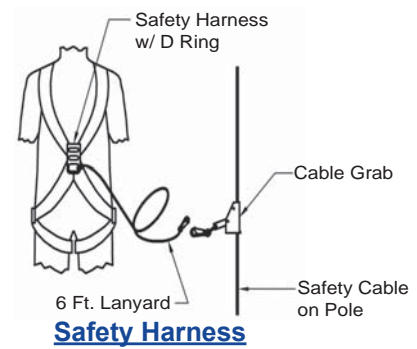

**Base Plate Detail**

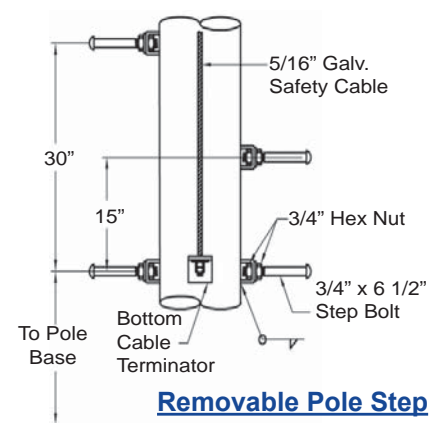

**Removable Pole Step**

# Sports Lighting Poles (Anchor Base)

Catalog Number	Pole Height (ft)	Pole Weight (lbs)	Anchor Bolts			Max Loading Capacities								Base Reactions		
			Bolt Circle (in)	Qty	Dimensions (in)	80 (mph)		90 (mph)		100 (mph)		110 (mph)		Axial (lbs)	Shear (lbs)	Moment (lbs)
						EPA (ft <sup>2</sup> )	Wt. (lbs)	EPA (ft <sup>2</sup> )	Wt. (lbs)	EPA (ft <sup>2</sup> )	Wt. (lbs)	EPA (ft <sup>2</sup> )	Wt. (lbs)			
RTS-501-AB	50	448	14.0	4	1.25 x 42 x 6	14	350	10	250	7	175	5	125	800	1300	41100
RTS-502-AB	50	645	14.0	4	1.25 x 42 x 6	23	575	18	450	14	350	11	275	1200	1600	58700
RTS-503-AB	50	755	15.5	4	1.50 x 54 x 6	32	800	25	625	20	500	16	400	1500	1900	73600
RTS-504-AB	50	856	16.5	4	1.50 x 54 x 6	41	1025	33	825	26	650	21	525	1800	2300	88700
RTS-505-AB	50	964	17.5	4	1.75 x 54 x 6	52	1300	41	1025	32	800	25	625	2200	2600	103100
RTS-506-AB	50	1268	18.0	4	1.75 x 54 x 6	71	1775	56	1400	45	1125	36	900	3000	3200	134500
RTS-601-AB	60	1025	17.0	4	1.50 x 54 x 6	26	650	20	500	16	400	13	325	1700	1800	77500
RTS-602-AB	60	1148	18.0	4	1.50 x 54 x 6	35	875	28	700	22	550	17	425	2000	2200	95600
RTS-603-AB	60	1553	20.5	8	1.50 x 54 x 6	62	1550	50	1250	40	1000	32	800	3000	3400	163800
RTS-604-AB	60	1695	21.5	8	1.50 x 54 x 6	81	2025	63	1575	49	1225	39	975	3400	4100	196100
RTS-701-AB	70	1228	18.0	4	1.50 x 54 x 6	22	550	17	425	13	325	10	250	1800	1900	86200
RTS-702-AB	70	1672	20.5	8	1.50 x 54 x 6	41	1025	33	825	26	650	21	525	2600	2800	145800
RTS-703-AB	70	1834	21.5	8	1.50 x 54 x 6	55	1375	42	1050	34	850	28	700	3100	3400	183200
RTS-704-AB	70	2033	22.5	8	1.50 x 54 x 6	75	1875	57	1425	44	1100	34	850	3800	4000	216400
RTS-705-AB	70	2150	23.0	10	1.50 x 54 x 6	82	2050	63	1575	49	1225	37	925	4000	4200	233300
RTS-801-AB	80	1946	21.5	8	1.50 x 54 x 6	39	975	28	700	22	550	19	475	2700	3000	170400
RTS-802-AB	80	2169	22.5	8	1.50 x 54 x 6	49	1225	39	975	32	800	25	625	3300	3600	211400
RTS-803-AB	80	2302	23.0	10	1.50 x 54 x 6	60	1500	48	1200	37	925	28	700	3700	4000	232500
RTS-804-AB	80	2493	24.0	10	1.50 x 54 x 6	72	1800	55	1375	42	1050	33	825	4100	4400	266000
RTS-805-AB	80	3481	25.5	8	1.75 x 54 x 6	111	2775	86	2150	67	1675	53	1325	6000	5800	377500
RTS-901-AB	90	2278	22.5	8	1.50 x 54 x 6	33	825	26	650	22	550	17	425	3000	3400	204100
RTS-902-AB	90	2425	23.0	10	1.50 x 54 x 6	40	1000	31	775	26	650	21	525	3300	3700	223100
RTS-903-AB	90	2636	24.0	10	1.50 x 54 x 6	51	1275	40	1000	31	775	24	600	3700	4200	263600
RTS-904-AB	90	3689	25.5	8	1.75 x 54 x 6	80	2000	64	1600	52	1300	41	1025	5400	5300	370000
RTS-101-AB	100	2573	23.0	10	1.50 x 54 x 6	27	675	23	575	18	450	14	350	2900	3900	233000
RTS-102-AB	100	2798	24.0	10	1.50 x 54 x 6	34	850	28	700	22	550	17	425	3300	4300	268100
RTS-103-AB	100	3359	27.0	10	1.50 x 54 x 6	65	1625	49	1225	37	925	26	650	4600	5600	369000
RTS-104-AB	100	4379	30.0	8	1.75 x 54 x 6	87	2175	68	1700	54	1350	40	1000	5600	7000	499800



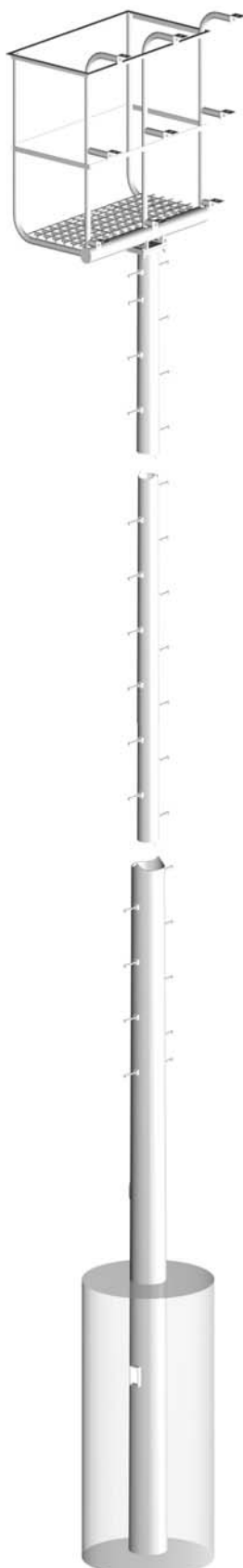

**Design**

The selection of the correct pole design is predicated on the specific loading requirements of each application. The poles located in the steel pole chart are designed to withstand dead loads and theoretical dynamic loads developed by sustained winds of 80 MPH through 110 MPH times the 1.3 gust factor. The combined EPA and the weight of the luminaire, light support brackets, platforms and any other attachments cannot exceed the rated EPA or allowable weight of that pole.

**Welding**

All welds shall be of the highest quality and performed by American Welding Society certified welders conforming to the latest version of the American Welding Society specification AWS D1.1.

**Finish**

All poles, mounting brackets and platforms are furnished with a coating of either red oxide/zinc primer, factory painted, powder coated or hot-dip galvanized to ASTM A-123. Miscellaneous hardware will be galvanized to ASTM A-153. Exterior finish coatings are available by request.

**Pole Shaft**

The steel pole shall consist of the appropriate number of pole sections, either round or multi-sided, for heights up to 120 feet. Each section shall be fabricated from high strength low alloy steel conforming to ASTM A-572, with a minimum yield strength of 55,000 psi. These shafts shall telescope over each other to match the overall desired pole height. The overlap telescoping joint shall have a length that is the larger of 2 feet or 1-1/2 times the diameter of the inside of the female tube. The sections shall be pre-fitted and match marked at the factory. All sections shall maintain a uniform taper from top to bottom. There shall be at least one longitudinal seam weld in the tapered section of the shaft. The longitudinal seam weld shall have at least 60% penetration, except in the areas where the shaft section telescopes over another. In overlapping areas, the weld penetration shall be 100%. No circumferential weld splices may be used in fabricating the shafts.

**Hand Hole**

An oval reinforced hand hole, having a nominal 4" x 6" x .25" wall, will be installed 18" above the groundline. A hand hole cover and attaching hardware is included with each hand hole assembly. A ground lug will be welded inside the pole opposite the hand hole. This is standard on all poles unless otherwise specified.

**Embedment**

The embedded portion of the pole which will be 10% of the free pole height + 2 feet, will include two 3" x 5" reinforced hand holes at 180 degrees apart, 24" below ground level for wire access. A 1/4" thick bearing plate will be integrally welded to the base of the shaft to aid in anti-rotation. As an option, a mastic coating may be applied at the ground level of the outer pole shaft +/- one foot to serve as added protection against the elements.

**Pole Top**

Each pole will be provided with either a removable pole cap, flat plate, or 2 3/8" O.D. x 5" tenon top (other sizes available).

**Complete factory pre-wired system available. Please consult factory for details.**

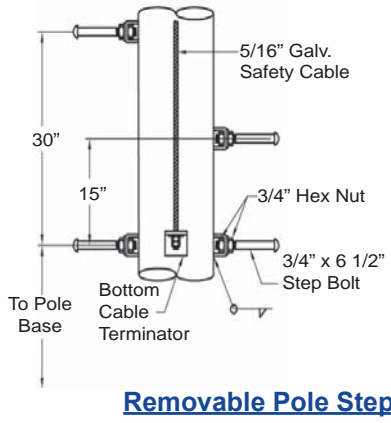
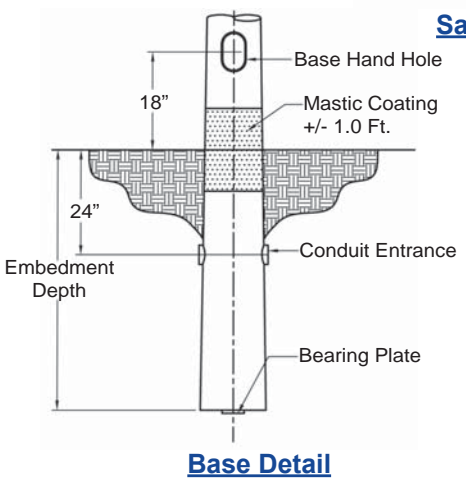
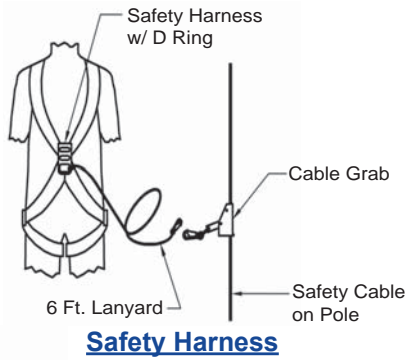

# Sports Lighting Poles (Direct Embedded)

Catalog Number	Mounting Height (ft)	Pole Weight (lbs)	Embedment Depth (ft)	Max Loading Capacities								Base Reactions		
				80 (mph)		90 (mph)		100 (mph)		110 (mph)		Axial (lbs)	Shear (lbs)	Moment (lbs)
				EPA (ft <sup>2</sup> )	Wt. (lbs)	EPA (ft <sup>2</sup> )	Wt. (lbs)	EPA (ft <sup>2</sup> )	Wt. (lbs)	EPA (ft <sup>2</sup> )	Wt. (lbs)			
RTS-501-DE	50	841	7.00	25	625	20	500	17	425	14	350	1300	1800	66900
RTS-502-DE	50	1039	7.00	42	1050	33	825	26	650	21	525	1900	2200	87100
RTS-503-DE	50	1255	7.00	52	1300	42	1050	33	825	27	675	2300	2600	104900
RTS-504-DE	50	1317	7.00	75	1875	59	1475	47	1175	39	975	2900	3500	147000
RTS-601-DE	60	1135	8.00	25	625	20	500	16	400	13	325	1700	1900	81400
RTS-602-DE	60	1456	8.00	47	1175	37	925	30	750	24	600	2500	2700	125600
RTS-603-DE	60	1594	8.00	60	1500	48	1200	39	975	31	775	3000	3300	159600
RTS-604-DE	60	1767	8.00	83	2075	64	1600	50	1250	39	975	3500	4100	196600
RTS-701-DE	70	1722	9.00	39	975	31	775	24	600	20	500	2600	2700	140000
RTS-702-DE	70	1922	9.00	53	1325	42	1050	34	850	28	700	3100	3400	183200
RTS-703-DE	70	2043	9.00	65	1625	52	1300	41	1025	32	800	3500	3800	209700
RTS-704-DE	70	2210	9.00	78	1950	60	1050	46	1150	36	900	3700	4500	238600
RTS-801-DE	80	2043	10.00	34	850	27	675	23	575	17	425	2700	3000	163900
RTS-802-DE	80	2180	10.00	41	1025	33	825	27	675	21	525	3000	3300	191000
RTS-803-DE	80	2369	10.00	53	1325	41	1025	33	825	26	650	3400	3800	224700
RTS-804-DE	80	3288	10.00	83	2075	66	1650	53	1325	44	1100	4900	5000	321100
RTS-901-DE	90	2337	11.00	30	750	21	525	18	450	13	325	2800	3000	173600
RTS-902-DE	90	2542	11.00	37	925	27	675	22	550	16	400	3200	3400	207900
RTS-903-DE	90	3442	11.00	59	1475	46	1150	37	925	29	725	4500	4400	289000
RTS-904-DE	90	3394	11.00	76	1900	58	1450	44	1100	32	800	4600	5500	349400
RTS-101-DE	100	3314	12.00	50	1250	39	975	29	725	21	525	3900	4800	312000
RTS-102-DE	100	3641	12.00	60	1500	44	1100	33	825	24	600	4400	5300	346300
RTS-103-DE	100	4063	12.00	71	1775	53	1325	39	975	28	700	4900	5900	390300
RTS-104-DE	100	4784	12.00	85	2125	66	1650	51	1275	40	1000	5900	6800	482500

